

Solutions through engineered products.

**NORRISEAL**  
A **DOVER** RESOURCES COMPANY

**Norriseal's Superior  
Encapsulated Design  
and Features**

**Norris Teflon Series  
T1011/T3011**

**Butterfly Valves**

PATENTED

**Sizes 2"-12" 125/150 ANSI**

Teflon® Seat Stainless Steel Disc

Teflon® Covered Seat with Teflon Covered Disc



*The Norriseal Valve line comes  
with new and improved  
patented designs and  
concepts.*



**A Lot More Valve  
For A Lot Less Cost.**

U.S. Patent #5207411  
Teflon® is a registered trademark of E.I. DuPont Co.



# Norris Teflon Series T1011/T3011

Sizes 2"-12"

PATENTED

**A Superior Sanitary Valve for the Chemical and Food Processing Industry**



## STANDARD FEATURES

**Top Plate** - Machined to standardized drilling pattern allowing manual handle kits, and actuation, interchangeability also available in ISO patterns.

**Stem Bushing** - Composed of full strength, corrosion resistant ertalyte, stem bushings absorb operator side thrust. Top bushing comes standard in all valves, while bottom bushing comes with all valves sizes 4"-12", to ensure trouble free valve operation.

**Stem-Seal** - A third seal ensuring absolute seal externally or internally for vacuum or pressure service.

**O-Seal (patented)** - Two Norris O-Seals give a positive secondary seal as the O-Seal becomes part of the body and encircles the stem before entering the seat and disc area. O-Seals are also located at top and bottom of stem entry to form an absolute secondary seal. Teflon® is standard.

**Seat** - Teflon® over Buna is standard, Teflon® over EPDM is optional.

**Hub Seal or Primary Seal** - Occurs when contact is made between the disc hub and the flat surface of the seat. Hub/seat seals prevent product from attacking stem or body.

**Body** - Lug style has drilled and tapped lugs meeting ANSI 125 and 150 flange standards. Two piece body allows ease of seat replacement. Lug body standard with Nodular Iron. Wafer body standard with Ductile Iron also available in Aluminum, Anodized Aluminum, Aluminum Bronze, Stainless Steel, Teflon® Coated and several Corrosion Resistant platings.

**Disc/Stem** - Norris' standard is 25-5, a duplex stainless which is more corrosion resistant and almost twice as strong as all other butterfly valve manufacturer's standard 316 stainless steel. This eliminates shaft twisting and water hammer damage and allows a thin disc design which increases CV rating without reducing strength. Also available in AVESTA 254 SMO with even more superior corrosion resistance. All encapsulated disc stems are 25-5 duplex stainless as standard which gives you approximately four times the corrosion resistance as 316 stainless steel and more strength too. Other materials are also available.

**Flange Seal** - Sealing O-Ring of resilient seat which provides an absolute seal to all flanges within specifications.

Patent #5207411

Every valve is tested to 110% of full pressure rating.

Teflon® and Vitor® are registered trademarks of E.I. DuPont Co.

254 SMO is a registered trademark of Avesta Sheffield

# The Difference Between Our Encapsulated Valve and Theirs? It's Night and Day.

Without Norris' Superior Encapsulated Design Product and/or cleaners can enter into the stem hole and attack the seat and stem.

## The Reason Why Norrisal is the Superior Encapsulated Valve on the Market Today.

The superior encapsulated design and features offer more than any other butterfly valve manufacturer on the market today. Norris' Teflon® line valve seat extends all the way through the shaft hole to the patented Teflon® O-Seal. The Teflon® encapsulated disc stem extends all the way through the Teflon® lined seat to the Teflon® O-Seal with no exposed rubber backing or metal disc stem like other manufacturers. Norris' encapsulated disc and stems are made of superior 254 SMO stainless steel which is far more corrosion resistant and stronger than other manufacturers standard 316 stainless steel encapsulated disc stem which stops stem twisting and water hammer damage. Norris offers a wide variety of rubber backings for lined seats including Viton®. Norris also offers elastomer encapsulated disc stems with its special blend of FDA approved nitrile for superior abrasion resistance also available in EPDM and numerous other materials. Norris' standard 255 stainless steel one piece disc stem or 254 SMO stainless steel one piece disc stem is so much more corrosion resistant than other butterfly manufacturers 316 stainless steel one piece disc stem you may be able to reduce your cost by not needing a full Teflon® valve to do the job.

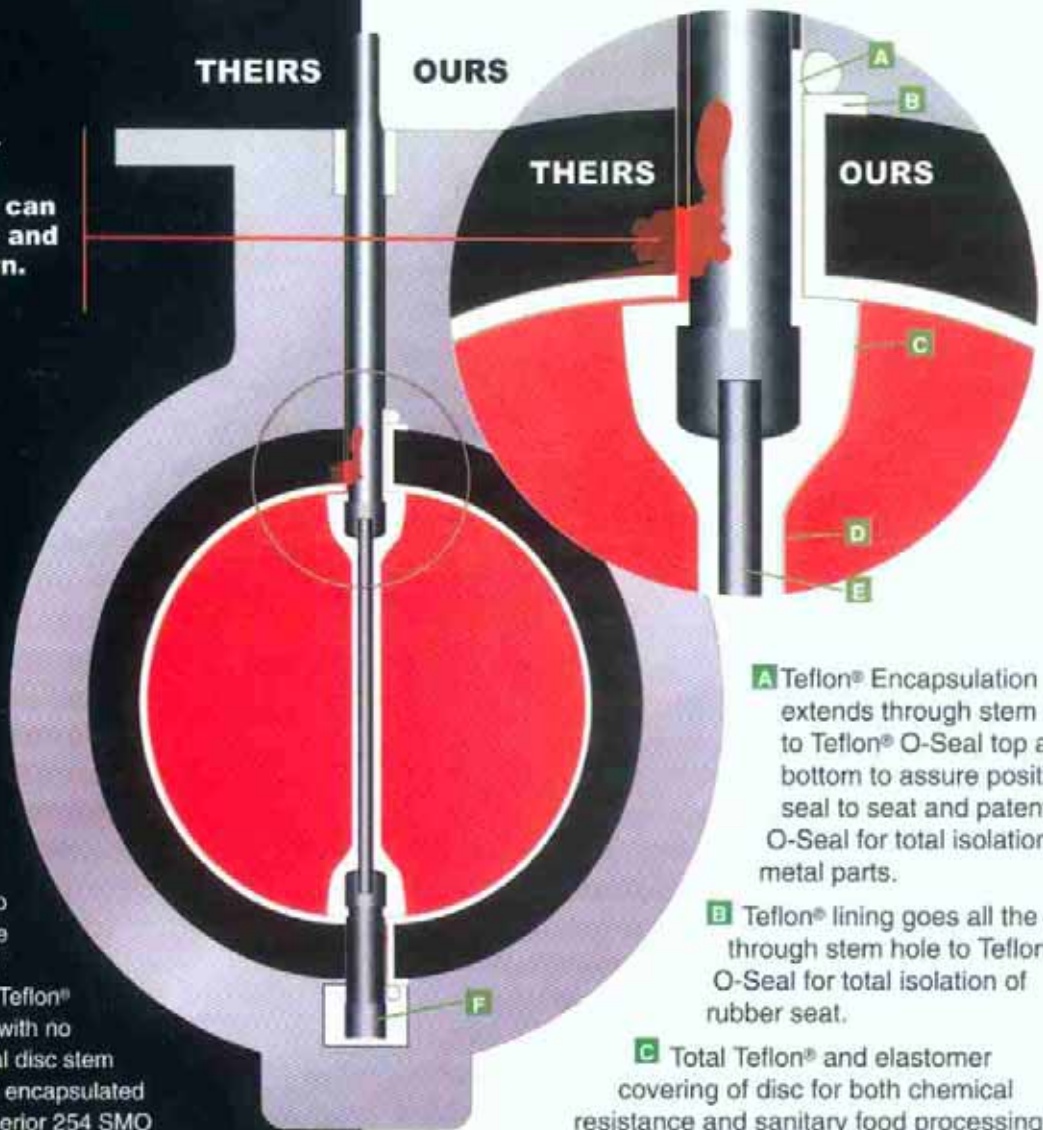

**A** Teflon® Encapsulation extends through stem hole to Teflon® O-Seal top and bottom to assure positive seal to seat and patented O-Seal for total isolation of metal parts.

**B** Teflon® lining goes all the way through stem hole to Teflon® O-Seal for total isolation of rubber seat.

**C** Total Teflon® and elastomer covering of disc for both chemical resistance and sanitary food processing.

**D** Slim disc for maximum flow.

**E** Norris' one piece disc and stem is standard 255 stainless steel which is several times more corrosion resistant and stronger than other manufacturers 316 stainless steel.

**F** Precision machined stems top and bottom to assure the proper seal and alignment to the ertalyte bushing with patented O-Seals for total secondary seal.



# Norris Teflon Series T1011/T3011

T1011 - Wafer

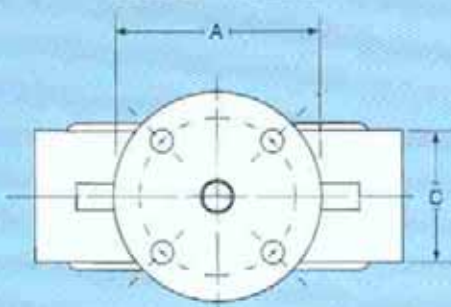

T3011 - Lug

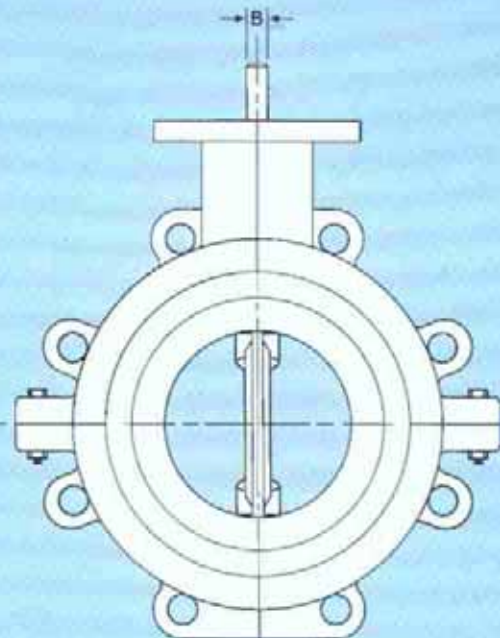
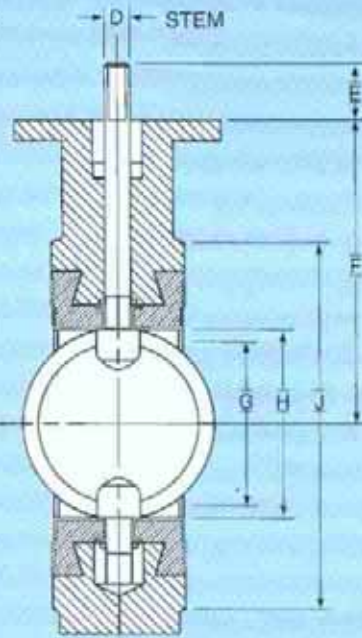
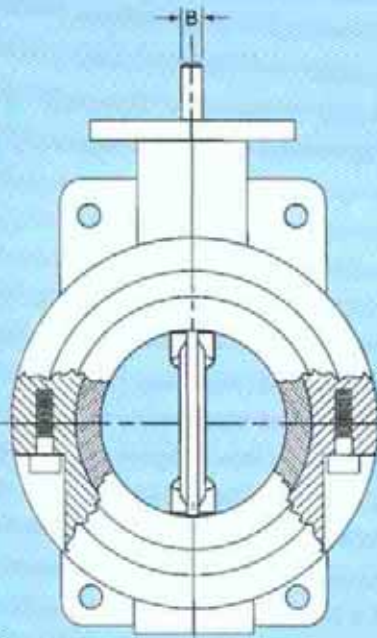
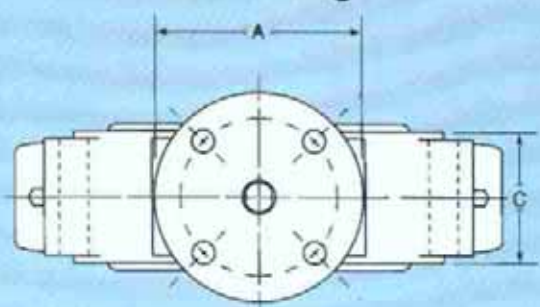

## Valve Size

Valve Dimension	2	2.5	3	4	5	6	8	10	12
A	4.000	4.000	4.000	4.000	4.000	4.000	6.000	6.000	6.000
B	.375	.375	.375	.438	.500	.500	.625	—	—
C	1.625	1.750	1.750	2.000	2.125	2.125	2.500	2.500	3.000
D	.563	.563	.563	.625	.750	.750	.875	1.125	1.125
E	1.250	1.250	1.250	1.250	1.250	1.250	1.250	2.000	2.000
F	3.938	4.500	4.875	6.000	6.000	6.500	8.313	9.000	10.719
G	1.375	2.062	2.563	3.625	4.750	5.500	7.500	9.594	11.563
H	2.000	2.500	3.000	4.000	5.000	5.750	7.750	9.750	11.750
J	4.125	4.825	5.375	6.750	7.750	8.750	10.875	13.250	16.063

### GENERAL NOTES:

- C = INSTALLED WIDTH
- G = MINIMUM ALLOWABLE INSIDE DIA. OF PIPE OR MATING FLANGE
- 2"-8" - D = STEM CONNECTION DIA.; B = FLATS
- 10" & 12" - D = STEM CONNECTION DIA.; KEYWAY = .250 x .250
- \*Weight based on 255 Stainless Steel disc/stem and Cast Iron Body.

## Top Plate Drilling

	2	2.5	3	4	5	6	8	10	12
No. Holes	4	4	4	4	4	4	4	4	4
Bolt Circle	3.250	3.250	3.250	3.250	3.250	3.250	5.000	5.000	5.000
Hole Dia.	.438	.438	.438	.438	.438	.438	.563	.563	.563

## Weight in Pounds\*

	2	2.5	3	4	5	6	8	10	12
T1011	6	8	9	11	15	17	29	44	85
T3011	8	10	11	17	21	26	42	65	108

## Lug Tapping Data

	2	2.5	3	4	5	6	8	10	12
Bolt Circle	4.750	5.500	6.000	7.500	8.500	9.500	11.750	14.250	17.000
No. Holes	4	4	4	8	8	8	8	12	12
Tap	.625-11 UNC			.750-10 UNC			.875-9 UNC		

**713/466-3552**  
**Fx: 713/896-7386**  
[www.norriseal.com](http://www.norriseal.com)

Solutions through engineered products.  
  
 A **DOVER** RESOURCES COMPANY  
 P.O. Box 40525 • Houston, Texas 77240-0525